

Adjustable Angle Plate

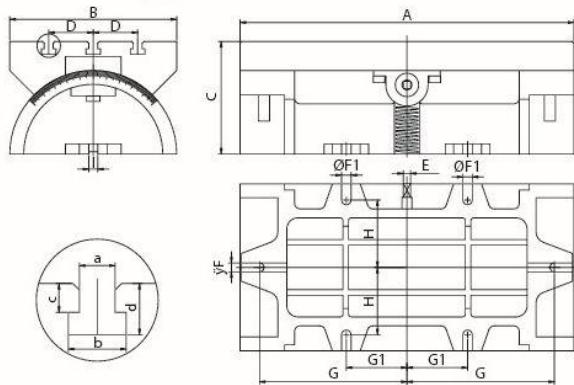

1. For angle setting on various machine tools.
2. Adjustable 45°
3. Material: FC25
4. Lower plate and bigger working space.



VP-600

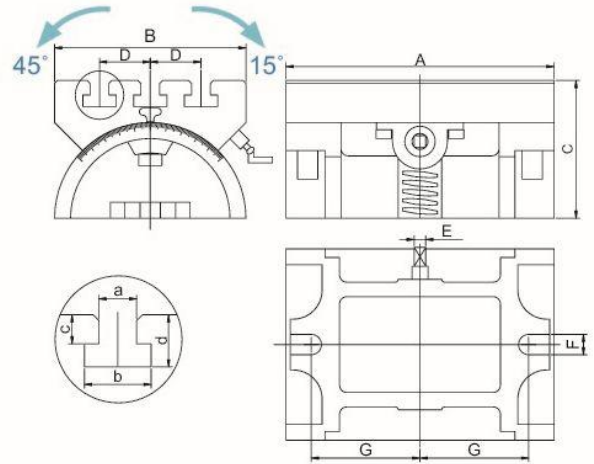

VP-180
VP-250
VP-380



Unit:mm

ORDER NO.	A	B	C	D	E	F	G	a	b	c	d	MAX. LOAD Capacity (kgs)	kg	CODE NO.
VP-180	185	132	95	35	8	14	75	13	23	10	18	6	7.38	1004-089
VP-250	255	180	136	50	10	16	95	16	26	13.5	25	10	28.7	1004-090
VP-380	380	255	181	69	13	18	150	16	26	14	25	18	56	1004-091

Unit:mm

ORDER NO.	A	B	C	D	E	F	F1	G	G1	H	I	a	b	c	d	MAX. LOAD Capacity (kgs)	kg	CODE NO.
VP-600	600	300	202	80	13	16	17	265	109	121	16	16	26	13	23	25	85	1004-092